

A. Notes:

- 1-1 The commonly used braking fluid for hydraulic disc brake has been divided into two series: DOT4 oil and Mineral oil. Please make sure the correct braking fluid to be used before installing the kits. (Incorrect oil grade may damage your braking system).
- 1-2 A professional and qualified technician with correct tools is required to install the kit correctly.
- 2. **Tools required:**
Torx wrench, hex wrench, open wrench, two sets of syringe+M5 and M5S connector +O-ring, clean wiper, MINERAL (DOT4) braking fluid:
- 3. **Exhausting the used old braking fluid:**
In exchanging new braking fluid, pressurize an empty syringe on one end and vacuum suck on the other end the used old braking fluid out (as shown in FIG. 1→2). Dispose the used oil to the qualified recycling agent.

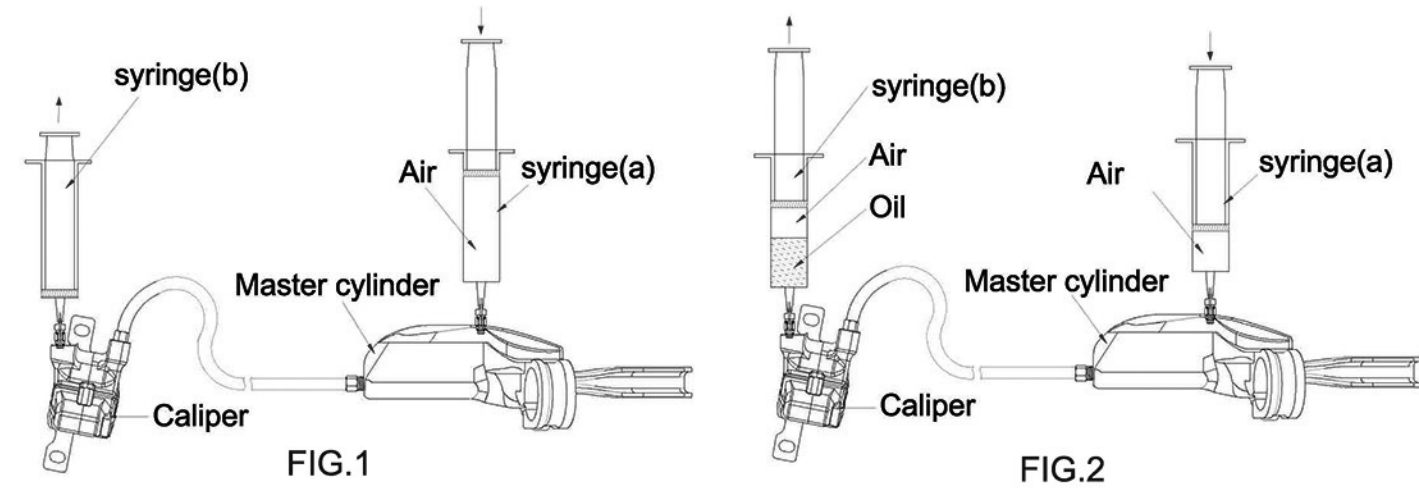

- 4. **The procedure of filling up braking fluid:**
- 4-1 Fix syringe (a) on the master cylinder via M5S and M5 connectors, fill up the designated syringe (b) for caliper on M5S and M5 connector the braking fluid in 90% full (about 25c.c.) Where, syringe should be of different brand and spec. to fit the connector, referred to the spec. list on right side.
- 4-2 Turn the nipple of oil trough up, loosen M5 fixing nut and fasten the syringe (a) onto the bleeder nipple tightly at 1~2Nm(9~18 in.lbs) (as shown in FIG.3)
- 4-3 Fasten the empty caliper syringe (b) to the bleeder nipple hole tight at 1~2Nm (9~18 in. lbs) (as shown in FIG.4)

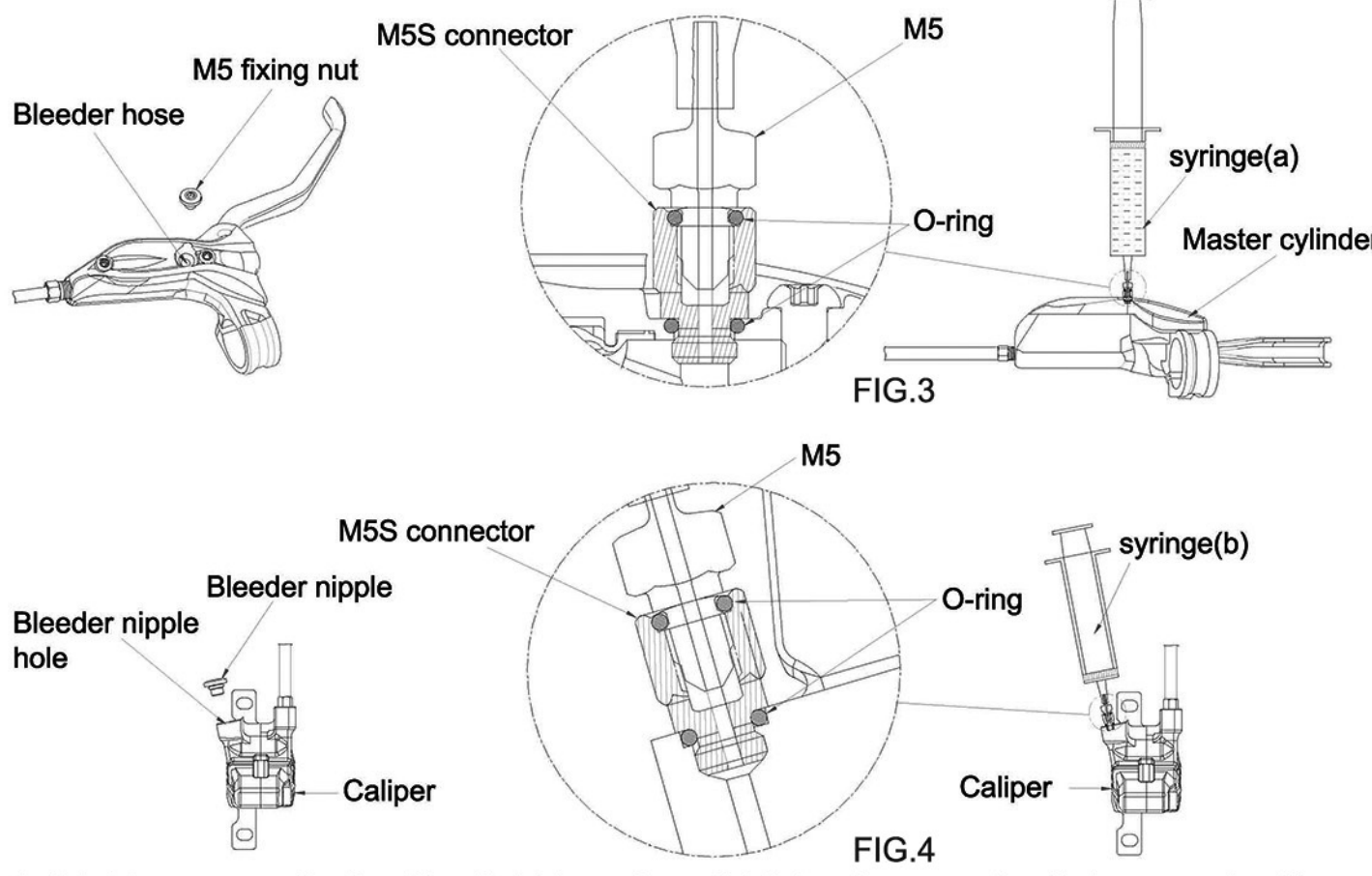

- 4-4 Light pressure the braking fluid in syringe (a) into oil reservoir, via hose and caliper into syringe (b). Then light pressure the fluid back to syringe (a)(as shown in FIG. 5). Repeat the process 3-4 times to expel the entrapped air along with pressing the handle and finally leave the fluid in syringe (a). Make sure keep syringes (a) and (b) at both end always remaining some fluid so as not to light pressure the air into the braking system.(Keep syringe up as shown in FIG.5)
- 4-5 Wrap the M5S connector for caliper with clothes to prevent braking fluid from overflowing, then take the syringe (b) off, fasten the bleeder nipple and wipe off the residual fluid. (Wipe fluid sludge by air spray gun and alcohol)
- 4-6 Light pressure the handle several times to verify the installation of braking system. Wrap the M5S connector and take off the syringe (a) set at the master cylinder side. Fasten M5 fixing nut and wipe the residual fluid off. (Wipe fluid sludge by air spray gun and alcohol)

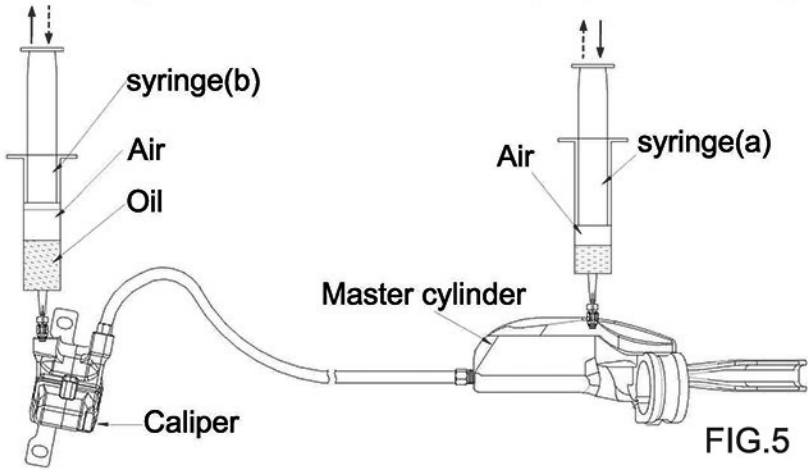

MINERAL Filling set		
Syringe + Connector		Brand/Spec
M5 Master cylinder M5S connector		SHIMANO M355/M395/M445 M446/M447/M505 ZEE XTR SAINT SLX XT DEORE
M5 Caliper M6L connector		
M5 Master cylinder		BENGAL ARES ARES 1
M5 Master cylinder Caliper M5S connector		
M5 Master cylinder M6 connector		TEKTRO AURIGA PRO AURIGA SUB AURIGA TWIN AURIGA E-COMP ORION/GEMINI VOLANS/DRACO HDC330/MOTA
M5 Caliper M7 connector		
M5 Master cylinder (mark) M6M connector(2014)		
M5 Caliper M6 connector		MAGURA MT 2/4/6/8
4MM PU tube		The primary pump comes with no filling nipple should fill the fluid in traditional way. Please refer to SHIMANO oil filling technique.
DOT4 Filling set		
Syringe + Connector		Brand/Spec
M5 Master cylinder Caliper M5S connector		AVID JUICY 3/3.5 JUICY 5/7 JUICY ULTIMATE ELIXIR 1/3/5 ELIXIR 7/9 ELIXIR R/CR CODE/5/R XX/XO
M5 Caliper		
M5 Master cylinder ø3 connector hole plug		HAYES NINE
M5 Master cylinder Caliper		HAYES STROKER TRAIL STROKER CARBON STROKER ACE STROKER GRAM STROKER RYDE RIME PRO PRIME EXPERT PRIME COMP PRIME SPORT DYNO
M5 Caliper M6 connector		
M5 Master cylinder M5L connector		

